

SCT SERIES - LP15

Shotcrete Remixer

- SCT6
- SCT7

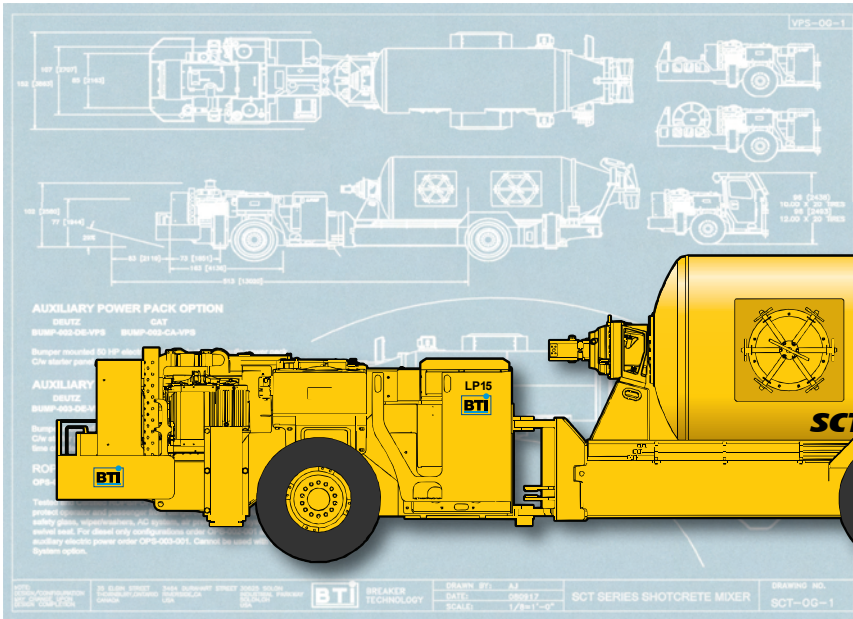

AT A GLANCE

Weights & Dimensions:

Operating Weight	Overall Trimming Length	Overall Width
SCT6: 45,000 lb (20,455 kg)	SCT6: 35'-6" (10.81 m)	7'-5" (2.26 m)
SCT7: 48,000 lb (21,820 kg)	SCT7: 36'-6" (11.13 m)	

Trimming Height	Carrier Articulation	Inside Turning Radius
8'-2" (2.5 m)	+/- 45°	16'-10" (5.1 m)

Note: Weights & dimensions are nominal and vary depending on final engine, operator's enclosure, & option configuration.	Outside Turning Radius
	28'-7" (8.7 m)

Engine Configurations:

- Deutz BF4M1013C 152 hp (113 kW) @ 2300 rpm MSHA/Tier II
- ▲ Mercedes 904 174 hp (130 kW) @ 2200 rpm Tier II
- ▲ Mercedes 906 201 hp (150 kW) @ 2200 rpm Tier II

Shotcrete Drum

- **SCT6**
Drum Capacity: 6 m³
Discharge Rate: 0 - 3 m³ per minute
Rotations/minute: 0 - 14 (both directions)
- ▲ **SCT7**
Drum Capacity: 7 m³
Discharge Rate: 0 - 3 m³ per minute
Rotations/minute: 0 - 14 (both directions)

FEATURES & BENEFITS

Heavy duty, low profile vehicle designed for remix operations in underground applications.

+/-45° vehicle articulation for tight turning radius

Separate torque converter / transmission package provides low profile engine shroud height for improved operator visibility.

Mid-ship operator compartment provides good visibility for trimming functions.

Optional 17" or 46" (432 or 1168 mm) heavy duty tube-in-tube self-leveling stabilizers provide quick set up times and stable operation.

Internal drum flutes provide remixing and material discharge without tilting the drum.

Drum speed controlled by two proportional joysticks; at the discharge end and at the operator's position.

Oval loading hatch front to rear, allows truck to be jockeyed for optimum loading.

OPTIONS

- Protective operator structure
- Seating configurations
- Tilting Remixer Drum
- Air intake system
- Exhaust system
- Fuel filling system
- Hydraulic filling system
- Tires
- Fire suppression system
- Auxiliary power pack
- Wheel chocks
- Drum tilt
- Stabilizers
- Catwalk/platforms
- Discharge chute
- Accelerator pumping system
- Form oil pumping system
- Pressure washer

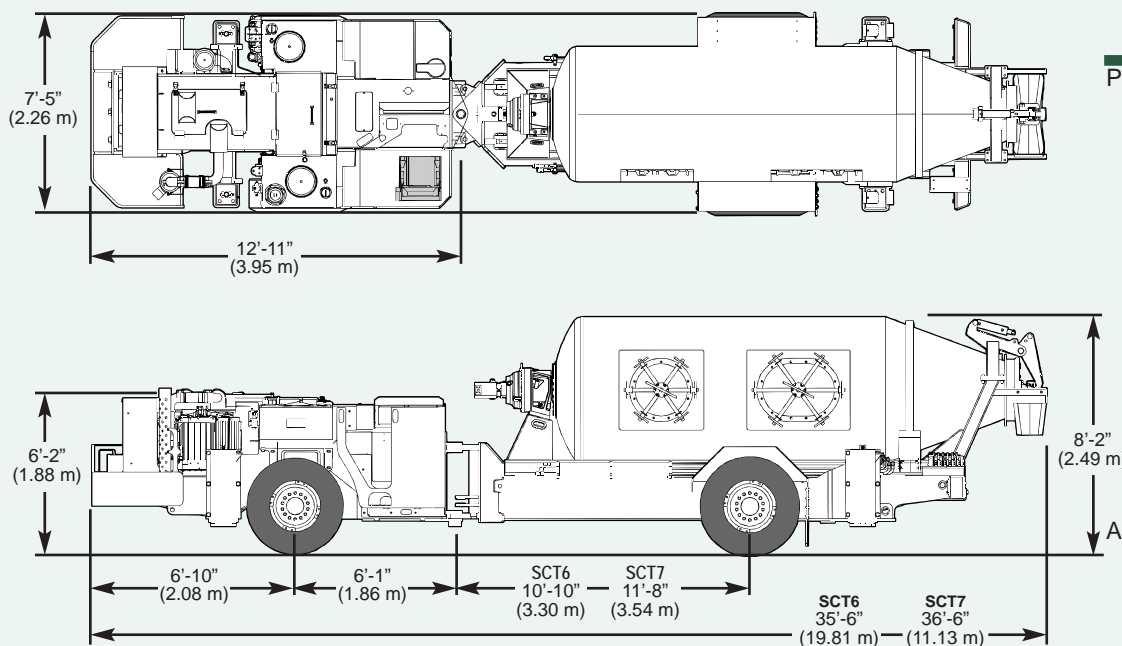

DRIVING SPECIFICATIONS

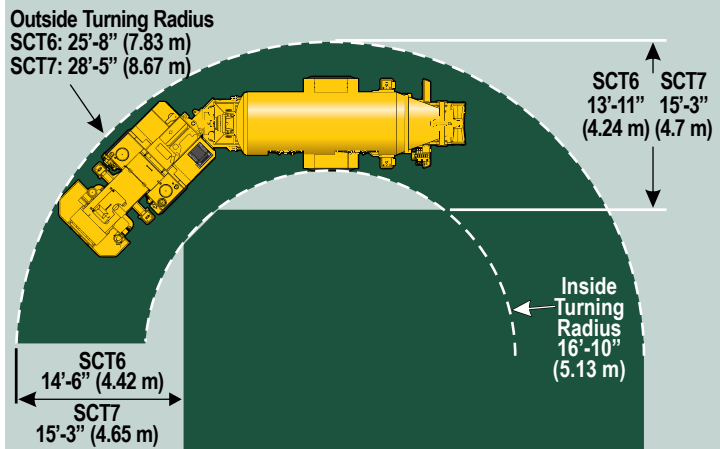

Turning Radius

Turning radius: +/- 45° articulation

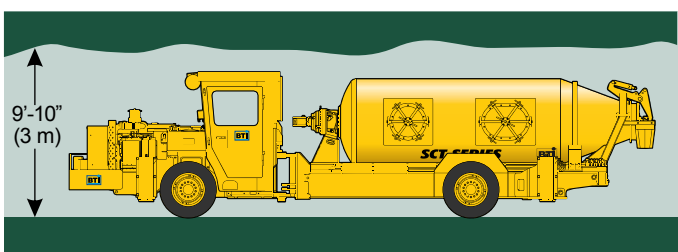

Recommended Drift Height

BTI recommends a minimum drift height with cab: 9'-10" (3 m)

LP15 CARRIER - COMMON FEATURES

- Standard - common to all engine combinations
- ▲ Optional

Notes:

● CHASSIS

LP15 articulated 4-wheel drive, all welded construction

● ENGINE END OSCILLATION

+/- 8° c/w heavy framed external walking beam

● CARRIER ARTICULATION

+/- 45° by two opposing 4" (100 mm) bore x 2" (50 mm) rod steering cylinders complete with stick steering control

● HYDRAULIC CIRCUIT

75 cc/rev hydraulic piston pump with load sense control
In-line hydraulic pressure filter
In-line return filter

● ELECTRICAL CIRCUIT

24 VDC start/run 100 amp alternator
Murphy Power Vu instrument cluster for electronic engines
Two LED red tram marker lights & two 70 watt halogen head lights on engine end
Two LED red tram marker lights & two 70 watt halogen head lights on boom end
Two 70 watt halogen working lights on boom end

REMIXER DRUM

Welded steel structure c/w internal flutes for mixing/emptying
Round inspection hatch and oval filling door
Hydraulic open/close rear discharge door
Hydraulic motor drive via high reduction gear box for high torque input

● SCT6 - 6 m³ drum capacity

▲ SCT7 - 7 m³ drum capacity

SCT CARRIER CONFIGURATIONS

Choose one per group

● Standard ▲ Optional

Notes:

POWERTRAIN GROUPS

- Deutz BF4M1013C
- ▲ Mercedes 904
- ▲ Mercedes 906

PROTECTIVE STRUCTURE

- Operator seating, no protective enclosure
- ▲ ROPS/FOPS canopy - Utility configuration, open air
- ▲ ROPS/FOPS fully enclosed cab full width (engine belt driven)
- ▲ ROPS/FOPS certified fully enclosed cab full width (hydraulic driven)

OPERATOR SEAT

- Suspension Seat
- ▲ Air Ride Seat

PASSENGER SEAT

- No passenger seat
- ▲ Suspension Seat
- ▲ Air Ride Seat

AIR INTAKE SYSTEM

- Air Intake Filter
- ▲ Air Intake Pre-cleaner

EXHAUST SYSTEM

- Catalytic exhaust
- ▲ Exhaust Manifold and Turbo Coating
- ▲ Exhaust System Wrap

FUEL SYSTEM

- Fuel Tank, 50 gallon (189 liter)
- ▲ Fuel Tank with Fast Fill, 50 gallon (189 liter)

HYDRAULIC TANK

- Hydraulic Tank, 50 gallon (189 liter)
- ▲ Hydraulic Tank with Fast Fill, 50 gallon (189 liter)

TIRES

- Pneumatic tires: 12:00 x 20; 20 ply
- ▲ Foam filled tires: 44.5 x 16.5; 30 ply

FIRE SUPPRESSION SYSTEM

- No fire suppression
- ▲ Fire Extinguisher, 1 x 20 lb (9 kg)
- ▲ Ansul Fire Suppression system
- ▲ Ansul Fire Suppression with Auto Detection

ELECTRIC POWER PACK

- No power pack
- ▲ 20 hp (15 kW) Electric motor driven hydraulic pump
- ▲ Pneumatic driven auxiliary power pack (backup power for unloading drum)

WHEEL CHOCKS

- No Wheel Chocks
- ▲ Aluminum Wheel Chocks

DRUM TILT

- SCT6 / SCT7 Drum, non-tilting
- ▲ SCT6 / SCT7 Tilting Drum

STABILIZERS

- No Stabilizers
- ▲ Engine End Stabilizers; 2 x 17" (432 mm), tube in tube configuration
- ▲ Mixer End Stabilizers; 2 x 17" (432 mm), tube in tube configuration
- ▲ Engine End Stabilizers; 2 x 46" (1.17 m), tube in tube configuration
- ▲ Mixer End Stabilizers; 2 x 46" (1.17 m), tube in tube configuration

CATWALK/PLATFORM

- No Catwalk/Platform
- ▲ LH catwalk c/w 42" (1.07 m) tall fixed safety rail & access ladder
- ▲ RH catwalk c/w 42" (1.07 m) tall fixed safety rail & access ladder
- ▲ LH catwalk c/w 42" (1.07 m) tall folding safety rail & access ladder
- ▲ RH catwalk c/w 42" (1.07 m) tall folding safety rail & access ladder

SCT CARRIER - COMMON FEATURES

Choose one per group

● Standard ▲ Optional

Notes:

DISCHARGE CHUTE

- No Discharge Chute
- ▲ Discharge chute complete with hydraulic lift and swing functions

ACCELERATOR PUMPING SYSTEM

- No Accelerator Pump System
- ▲ Hydraulic on board mounted pump, c/w 40 gallon (151 liter) tank
- ▲ Pneumatic on board mounted pump, c/w 40 gallon (151 liter) tank

FORM OIL PUMPING SYSTEM

- No Form Oil Pump System
- ▲ On board Form Oil pump, c/w 24 gallon (91 liter) tank

PRESSURE WASHER

- No Pressure Washer
- ▲ On board mounted pressure washer

POWERTRAIN GROUP OPTIONS

● Standard ▲ Optional

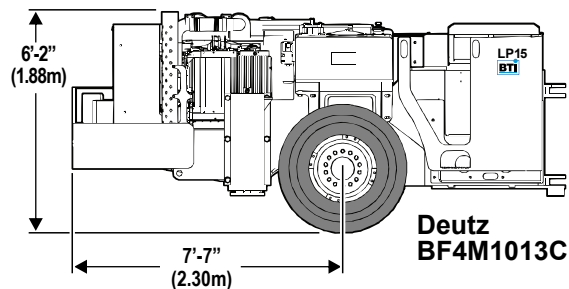

- **Engine:** Deutz BF4M1013C, four cylinder, turbocharged, intercooled diesel, MSHA/Tier II, 152 hp (113 kW) @ 2300 rpm c/w fuel filter and water separator
- Torque converter:** Clark C270 series
- Transmission:** Clark 32,000 series, long drop, remote mounted, electric shift
- Three forward and three reverse speeds
- Vehicle speeds with 12 x 20 tires @ 2200 rpm with standard axle ratio:
1st gear: 2.4 mph (3.9 kph) • **2nd:** 6.2 mph (10.0 kph) • **3rd:** 11.4 mph (18.3 kph)
- Engine end axle:** John Deere 1400 series, no-spin differential, c/w external walk ing beam. Wet disk SAHR emergency brakes, wet disk HASR service brakes.
- Remixer end axle:** John Deere 1400 series, no-spin differential. Wet disk SAHR emergency brakes, wet disk HASR service brakes.
- Drivelines:** Mechanics 6C and 7C

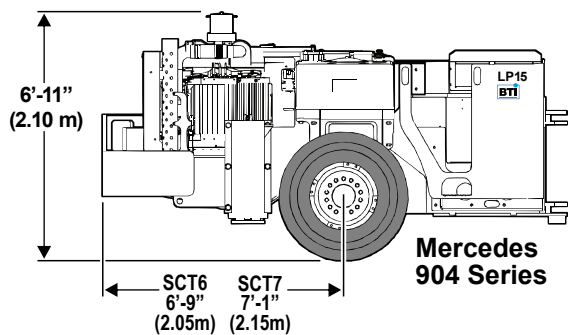

- ▲ **Engine:** Mercedes 904, four cylinder, turbocharged, intercooled diesel, Tier II, 174 hp (130 kW) @ 2200 rpm c/w fuel filter and water separator
- Torque converter:** Clark C320 series
- Transmission:** Clark 32,000 series, long drop, remote mounted, electric shift
- Three forward and three reverse speeds
- Vehicle speeds with 12 x 20 tires @ 2200 rpm with standard axle ratio
1st gear: 2.8 mph (4.5 kph) • **2nd:** 5.8 mph (9.3 kph) • **3rd:** 14.8 mph (23.8 kph)
- Engine end axle:** John Deere 1400 series, no-spin differential, c/w external walking beam. Wet disk SAHR emergency brakes, wet disk HASR service brakes.
- Remixer end axle:** John Deere 1400 series, no-spin differential. Wet disk SAHR emergency brakes, wet disk HASR service brakes.
- Drivelines:** Mechanics 6C and 7C

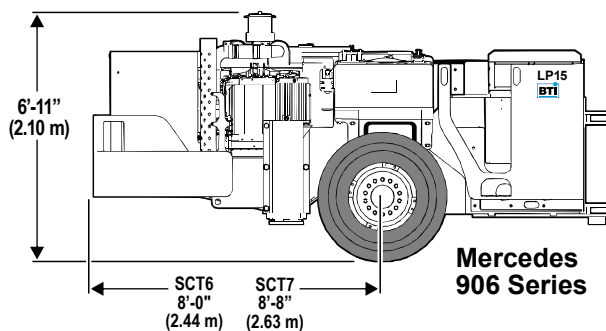

- ▲ **Engine:** Mercedes 906 Series, six cylinder, turbocharged, intercooled diesel, Tier II, 201 hp (150 kW) @ 2520 rpm c/w fuel filter and water separator.
- Torque converter:** Clark C320 series
- Transmission:** Clark 32,000 series, long drop, remote mounted, electric shift
- Three forward and three reverse speeds
- Vehicle speeds with 12 x 20 tires @ 2200 rpm with standard axle ratio
1st gear: 2.8 mph (4.5 kph) • **2nd:** 5.8 mph (9.3 kph) • **3rd:** 14.8 mph (23.8 kph)
- Engine end axle:** John Deere 1400 series, no-spin differential, c/w external walking beam. Wet disk SAHR emergency brakes, wet disk HASR service brakes.
- Remixer end axle:** John Deere 1400 series, no-spin differential. Wet disk SAHR emergency brakes, wet disk HASR service brakes.
- Drivelines:** Mechanics 6C and 7C

PROTECTIVE STRUCTURES OPTIONS

● Standard ▲ Optional

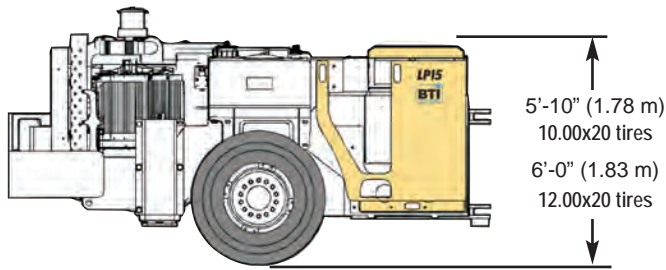

● Standard Operator Compartment

Standard dual compartments for operator and passenger.

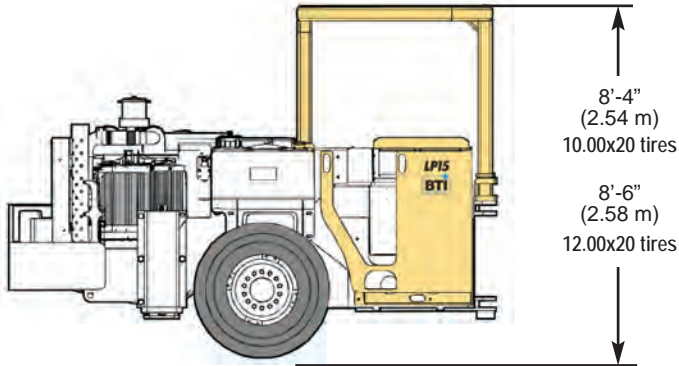

▲ ROPS/FOPS Canopy

Tested and certified ROPS/FOPS canopy, complete with guard bars to help protect operator and passenger from dangerous fly-rock. Complete with swivel operator seat.

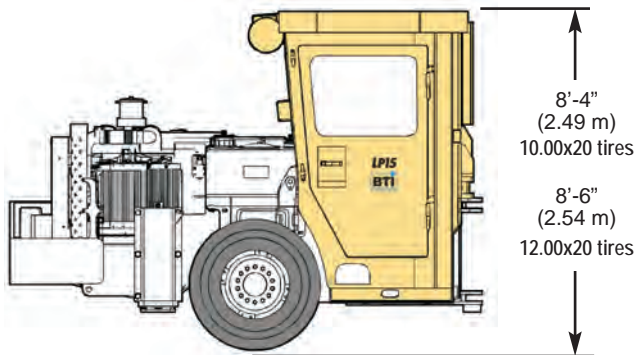

ROPS/FOPS Cab

▲ Engine Belt Driven ▲ Hydraulic Driven

Fully enclosed cab; covers operator, controls and passenger. Tested and certified ROPS/FOPS cab, complete with guard bars to help protect operator and passenger from dangerous fly-rock. Includes heavy-duty safety glass, wiper/washers, HVAC heat / air conditioning system, air pressurization system and operator swivel seat.

Either engine belt driven air conditioner for engine driven applications, or hydraulic driven air conditioner for electric driven power pack applications.

OPERATOR SEAT OPTIONS

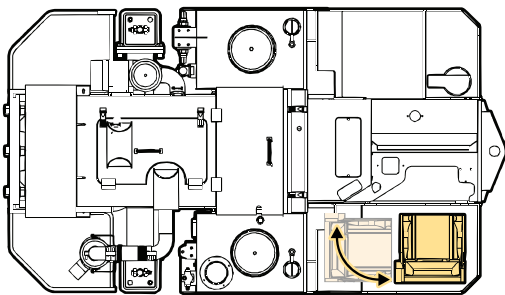

Operator Seat Options

● Suspension Seat ▲ Air Ride Seat

Mine duty operator seat options available in suspension and air ride variations.

PASSENGER SEAT OPTIONS

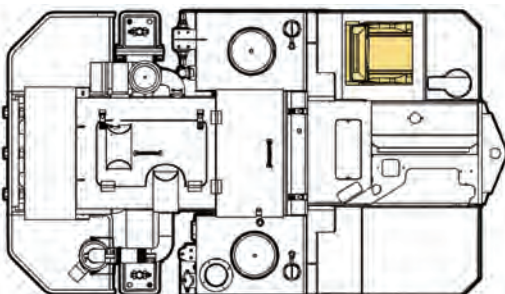

● No Passenger Seat

Passenger Seat Options

▲ Suspension Seat ▲ Air Ride Seat

Mine duty passenger seat options available in suspension and air ride variations.

AIR INTAKE SYSTEM OPTIONS

● Standard ▲ Optional

● Air Intake Filter

A dry element filter with safety element and replacement indicator.

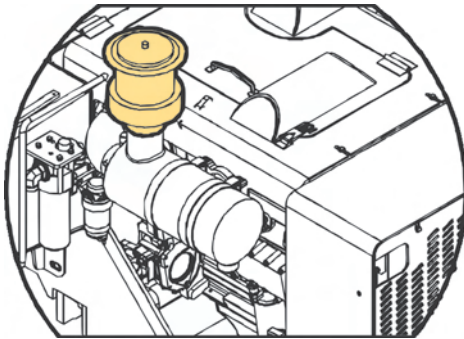

▲ Air Intake Precleaner

A dry element filter with safety element and replacement indicator, complete with a cyclone Pre-cleaner.

A pre-cleaner extends the life of your air filter by removing dirt and contaminants before they reach the filter and ejecting them automatically via the exhaust.

EXHAUST SYSTEM OPTIONS

● Catalytic Exhaust

A catalytic exhaust, purifier/silencer. No exhaust blanket.

▲ Exhaust Manifold and Turbo Coating

Prevents fluids from igniting on hot engine and exhaust parts. High temperature performance: ideal for engine compartment components requiring long-term exposure to high temperatures.

Non-flammable. Protects personnel from burns.

Lowers ambient temperature; cooler engine compartment, less heat stress on operators and maintenance personnel.

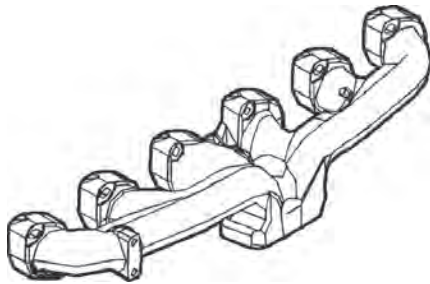

▲ Exhaust System Wrap

Prevents fluids from igniting on exhaust parts. High temperature performance.

Non-flammable. Protects personnel from burns.

Lowers ambient temperature; cooler engine compartment, less heat stress on operators and maintenance personnel.

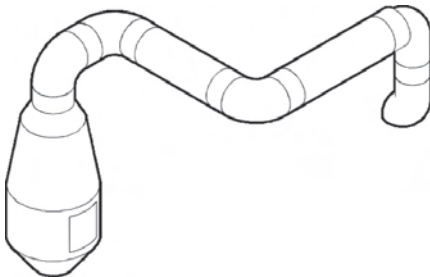

FUEL TANK OPTIONS

● Fuel Tank

50 gallon (189 liter) fuel tank, top fill.

▲ Fuel Tank with Fast Fill

50 gallon (189 liter) fuel tank complete with Fast Fill filling system. Designed for on-site fast fluid transfer.

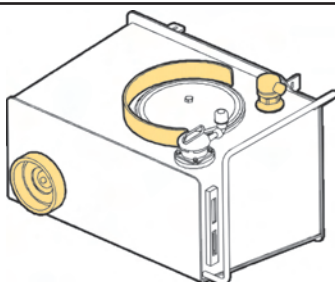

HYDRAULIC TANK OPTIONS

- Standard
- ▲ Optional

● Hydraulic Tank

50 gal (189 liter) hydraulic tank, top fill, 4 psi pressurized cap.

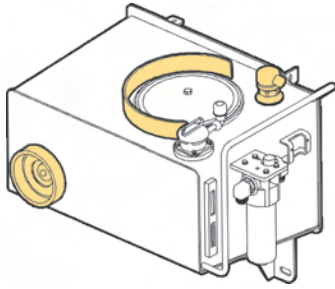

▲ Hydraulic Tank with Fast Fill

50 gal (189 liter) hydraulic tank complete with Fast Fill filling system. Designed for on-site fast fluid transfer.

TIRE OPTIONS

● Pneumatic Tires

12:00 x 20; 20 ply

FIRE SUPPRESSION SYSTEM OPTIONS

● No Fire Suppression System

▲ Fire Extinguisher

1 x 20 lb (9 kg) fire extinguisher.



▲ Ansul Fire Suppression

Ansul fire suppression system, 6 nozzle, complete with 2 actuators and a 20 lb (9 kg) fire extinguisher.

▲ Ansul Fire Suppression with Detection

Ansul fire suppression system, 6 nozzle, complete with 2 actuators. Includes a check fire detection and activation system. Complete with a 20 lb (9 kg) fire extinguisher.

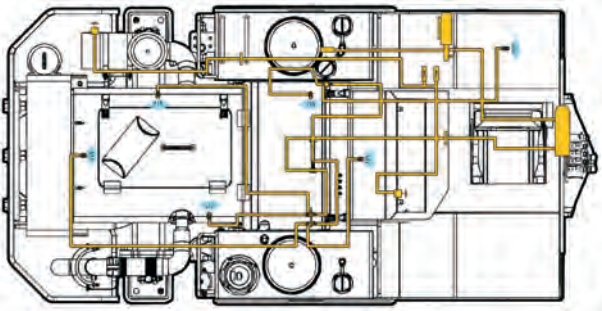

AUXILIARY POWER PACK OPTION

● No Auxiliary Power Pack

▲ Auxiliary Power Pack - Electric

20 HP (15 kW) Electric motor driven hydraulic pump, mounted to mixer end frame. Meant to serve as a backup power for offloading the drum.

▲ Auxiliary Power Pack - Pneumatic

Pneumatically driven fixed displacement pump. Meant to serve as a backup power for offloading the drum.

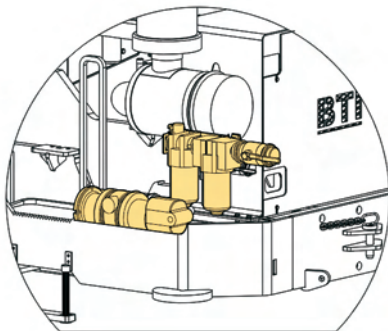

WHEEL CHOCK OPTIONS

- Standard
- ▲ Optional



● No Wheel Chocks

▲ Wheel Chocks - aluminum

Complete with holder

SCT6 TILTING DRUM OPTIONS

● SCT6 DRUM

Six cubic meter capacity, non-tilting drum. Continuously adjustable drum rotation between 0 and 14 rpm, in both turning directions. Drum speed is controlled by two proportional joysticks, one at the discharge end of the drum, the other at the operator's position.

▲ SCT6 TILTING DRUM

The tilting drum allows more clearance over the shotcrete gun and provides equal distribution of the shotcrete while loading the drum.

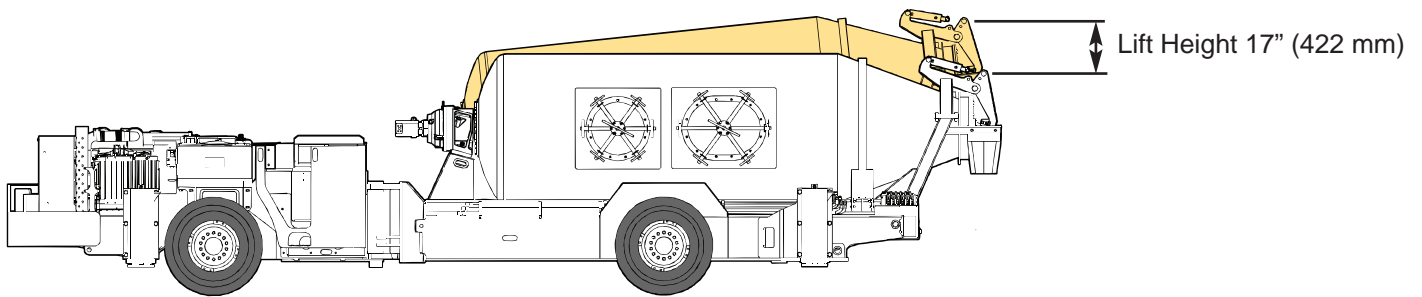

SCT7 TILTING DRUM OPTIONS

● SCT7 DRUM

Seven cubic meter capacity, non-tilting drum. Continuously adjustable drum rotation between 0 and 14 rpm, in both turning directions. Drum speed is controlled by two proportional joysticks, one at the discharge end of the drum, the other at the operator's position.

▲ SCT7 TILTING DRUM

The tilting drum allows more clearance over the shotcrete gun and provides equal distribution of the shotcrete while loading the drum.

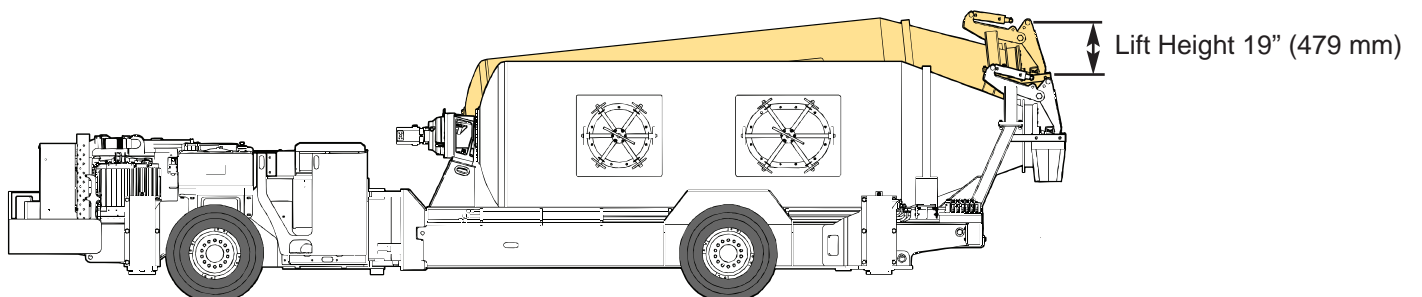

STABILIZER OPTIONS

- Standard
- ▲ Optional

Engine-end/Mixer-end Stabilizers: 2 x 17" (432 mm)

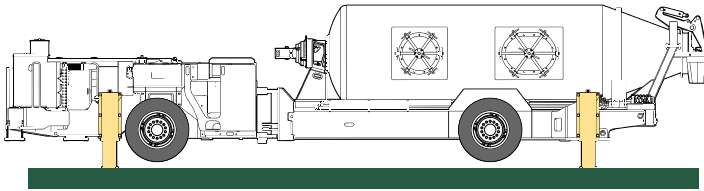

Engine-end/Mixer-end Stabilizers: 2 x 46" (1.17 m)

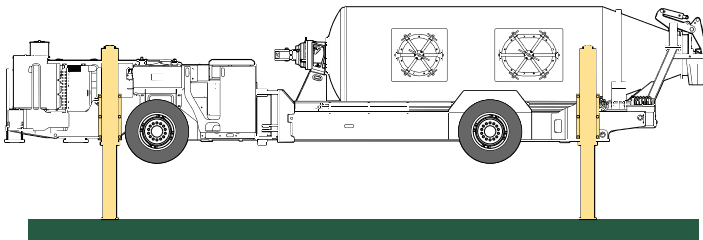

Engine-end Stabilizers: 2 x 46" (1.17 m)
Mixer-end Stabilizers: 2 x 17" (432 mm)

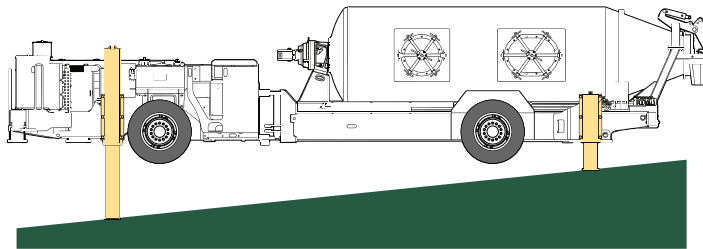

● No Stabilizers

No stabilizers are needed if the mining application does not require stabilizers to lift the vehicle

Stabilizers

- ▲ Engine-end Stabilizers: 2 x 17" (432 mm)
- ▲ Engine-end Stabilizers: 2 x 46" (1.17 m)
- ▲ Mixer-end Stabilizers: 2 x 17" (432 mm)
- ▲ Mixer-end Stabilizers: 2 x 46" (1.17 m)

Engine-end stabilizers enable you to keep the vehicle horizontal for better discharge of concrete when pointing down a ramp or incline.

Mixer-end stabilizers allow you to raise the mixer drum discharge higher, providing better clearance and angle when transferring concrete to the shotcrete sprayer. They permit levelling the vehicle on downgrades and make it convenient to raise the truck for changing flat tires.

RH CATWALK PLATFORM

● No Catwalk

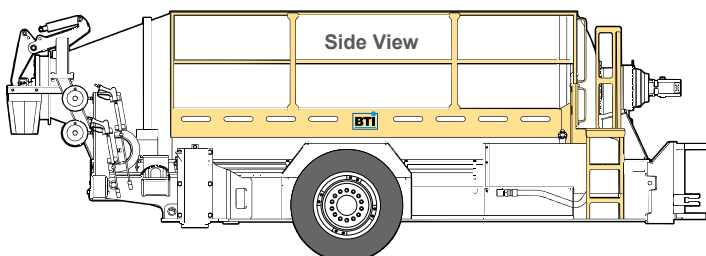
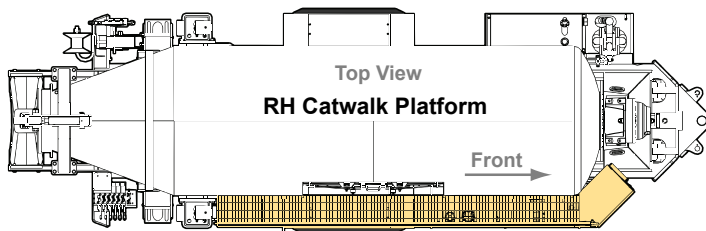

Catwalk Options

- ▲ Right-hand Catwalk c/w 3'-6" (1.07 m) tall fixed safety rail and access ladder
- ▲ Right-hand Catwalk c/w 3'-6" (1.07 m) tall folding safety rail and access ladder

The catwalk/platform structure allows the operator to quickly and safely access the drum hatches for filling and inspection.

The catwalk is complete with 3'-6" (1.07 m) tall safety rail and access ladder. It includes either a fixed or removable handrail/ladder at mixer discharge end.

LH CATWALK PLATFORM

- Standard
- ▲ Optional

● No Catwalk

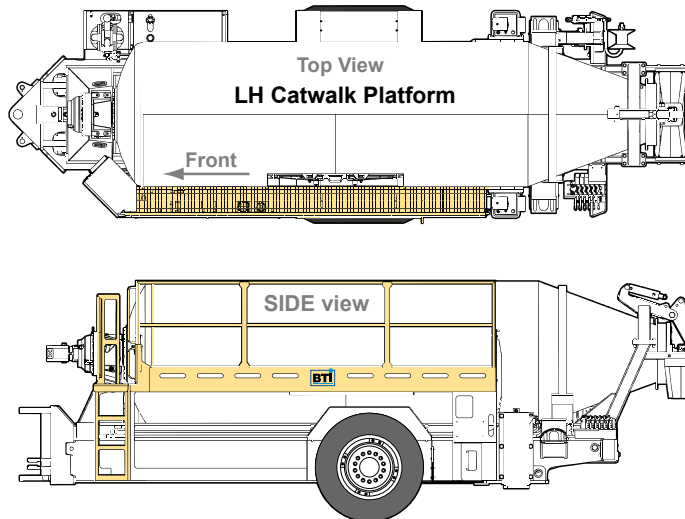

Catwalk Options

- ▲ Left-hand Catwalk c/w 3'-6" (1.07 m) tall fixed safety rail and access ladder
- ▲ Left-hand Catwalk c/w 3'-6" (1.07 m) tall folding safety rail and access ladder

The catwalk/platform structure allows the operator to quickly and safely access the drum hatches for filling and inspection.

The catwalk is complete with 3'-6" (1.07 m) tall safety rail and access ladder. It includes either a fixed or removable handrail/ladder at mixer discharge end.

DISCHARGE CHUTE OPTIONS

● No Discharge Chute

▲ Discharge Chute

The discharge chute with hydraulic controlled tilt and swing capability (+/- 90°) allows the operator to adjust the chute at any position without strain or effort. This allows the operator to put the concrete/shotcrete exactly where it's needed.

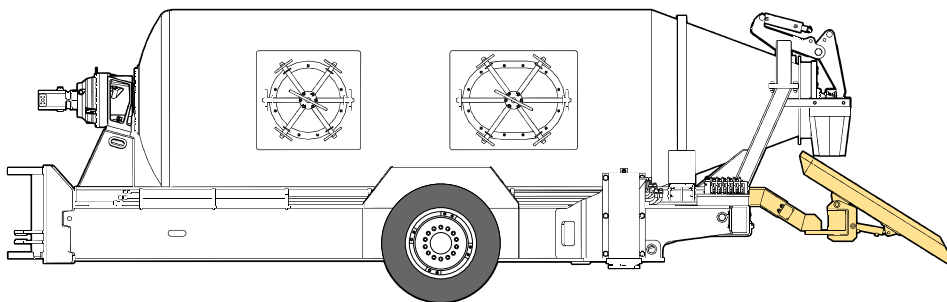

ACCELERATOR PUMPING SYSTEM OPTION

● No Accelerator

- ▲ Hydraulic Pump, Tank & Reel
- ▲ Pneumatic Pump, Tank & Reel

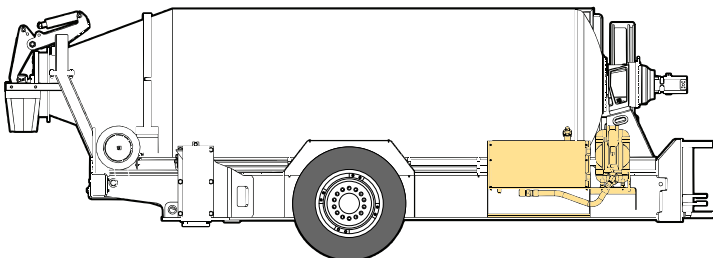

Stainless steel, 40 gallon (151 liter) tank, with a hydraulic or pneumatic pump and 50' (15.2 m) hose reel. The accelerator tank and pump allow the operator to transport accelerator solution (concrete curing agent) to the spray site and transfer the solution to the shotcrete sprayer tank, where it is applied to the concrete.

FORM OIL PUMPING SYSTEM OPTION

● Standard ▲ Optional

● No Form Oil Sprayer

▲ Form Oil Sprayer

Hydraulic pump with 24 gallon (90.8 liter) tank and 50' (15.2 m) hose reel.

Form oil prevents the concrete from sticking to metal surfaces. The form oil sprayer allows the operator to spray the form oil on the drum, hatch and surfaces that come in contact with the concrete.

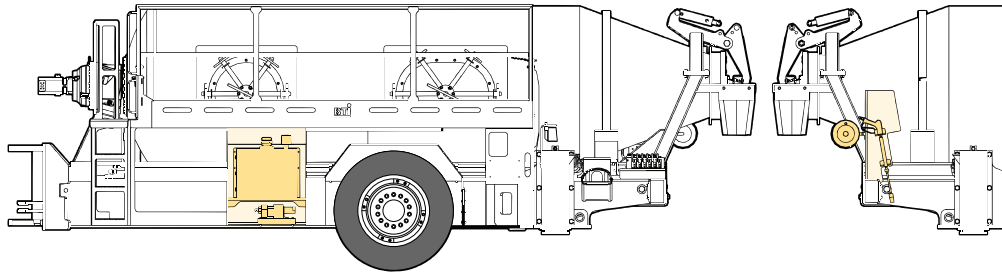

PRESSURE WASHER OPTIONS

● No Pressure Washer

▲ Pressure Washer Option

Onboard mounted hydraulic pressure washer complete with 50' (15.2 m) hose and spray wand. No tank; 3/4" NPT hookup for mine water.

The pressure washer allows the operator the ability to clean his vehicle where ever there is a water source. The mixer can also be cleaned at the site, preventing concrete from building up on any surfaces.

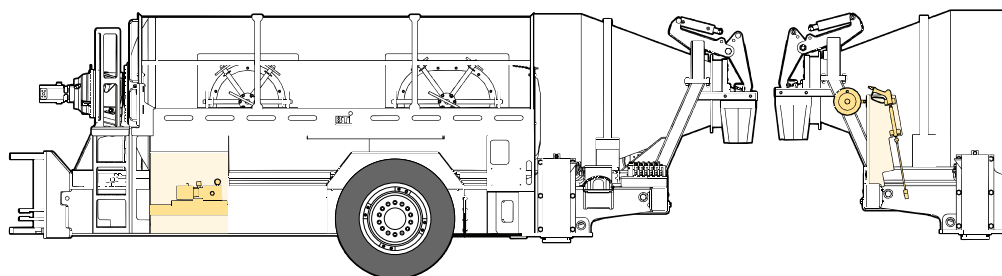

10459-ENG-1009

All dimensions and specifications are subject to change without notice.

BREAKER TECHNOLOGY an Astec Industries Company

UNITED STATES EAST 440.248.7168 • UNITED STATES WEST 951.369.0878 • CANADA/INTERNATIONAL 519.599.2015 • rockbreaker.com

